



**Robert Bosch GmbH**  
Power Tools Division  
70745 Leinfelden-Echterdingen  
Germany

[www.bosch-pt.com](http://www.bosch-pt.com)

2 609 140 769 (2010.08) T / 268 UNI



2 609 140 769

## GOP 250 CE Professional

 **BOSCH**

<b>de</b> Originalbetriebsanleitung	<b>el</b> Πρωτότυπο οδηγιών χρήσης	<b>sr</b> Originalno uputstvo za rad
<b>en</b> Original instructions	<b>tr</b> Orijinal işletme talimatı	<b>sl</b> Izvirna navodila
<b>fr</b> Notice originale	<b>pl</b> Instrukcja oryginalna	<b>hr</b> Originalne upute za rad
<b>es</b> Manual original	<b>cs</b> Původní návod k používání	<b>et</b> Algupärane kasutusjuhend
<b>pt</b> Manual original	<b>sk</b> Pôvodný návod na použitie	<b>lv</b> Instrukcijas oriģinālvalodā
<b>it</b> Istruzioni originali	<b>hu</b> Eredeti használati utasítás	<b>lt</b> Originali instrukcija
<b>nl</b> Oorspronkelijke gebruiksaanwijzing	<b>ru</b> Оригинальное руководство по эксплуатации	<b>ar</b> تعليمات التشغيل الأصلية
<b>da</b> Original brugsanvisning	<b>uk</b> Оригінальна інструкція з експлуатації	<b>fa</b> راهنمای طرز کار اصلی
<b>sv</b> Bruksanvisning i original	<b>ro</b> Instrucțiuni originale	
<b>no</b> Original driftsinstruks	<b>bg</b> Оригинална инструкция	
<b>fi</b> Alkuperäiset ohjeet		



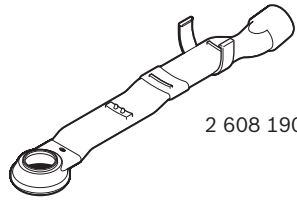

2 608 190 054



HCS:  
2 608 661 643 (Ø 85 mm, 1x)  
BIM:  
2 608 661 636 (Ø 85 mm, 1x)



2 608 661 642  
(Ø 85 mm)



HCS:  
2 608 661 637 (32 mm, 1x)  
2 608 661 626 (32 mm, 5x)  
2 608 661 638 (20 mm, 1x)  
2 608 661 627 (20 mm, 5x)  
2 608 661 639 (10 mm, 1x)

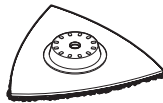

2 608 661 648  
(78 mm)

BIM:  
2 608 661 640 (20 mm, 1x)  
2 608 661 628 (20 mm, 5x)  
2 608 661 641 (10 mm, 1x)



2 608 661 646

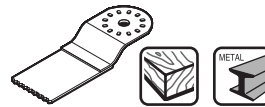

BIM:  
2 608 661 644 (28 mm, 1x)  
2 608 661 629 (28 mm, 5x)



2 608 661 647

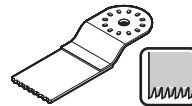

2 608 000 353

BIM:  
2 608 661 645 (32 mm, 1x)  
2 608 661 630 (32 mm, 5x)



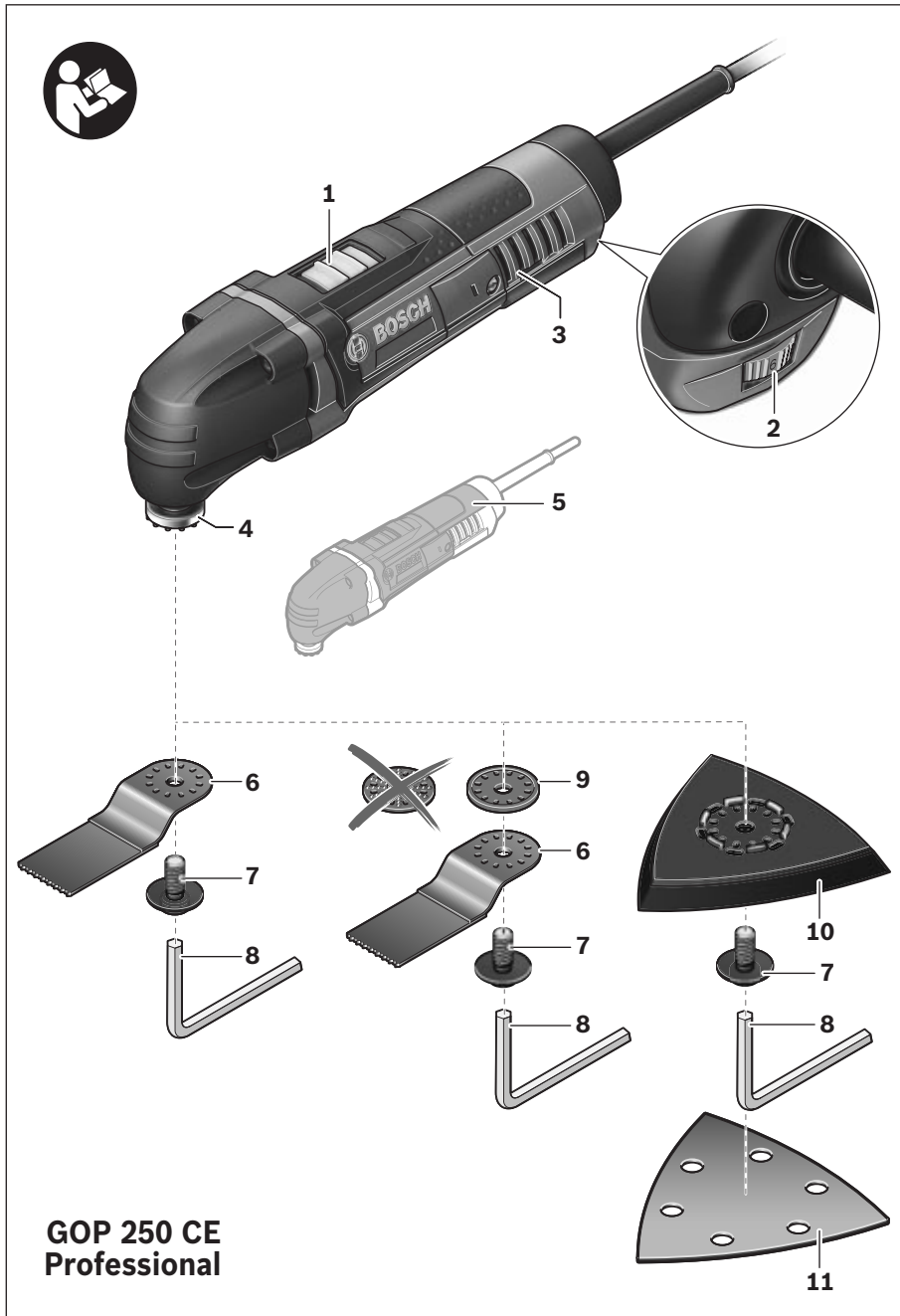

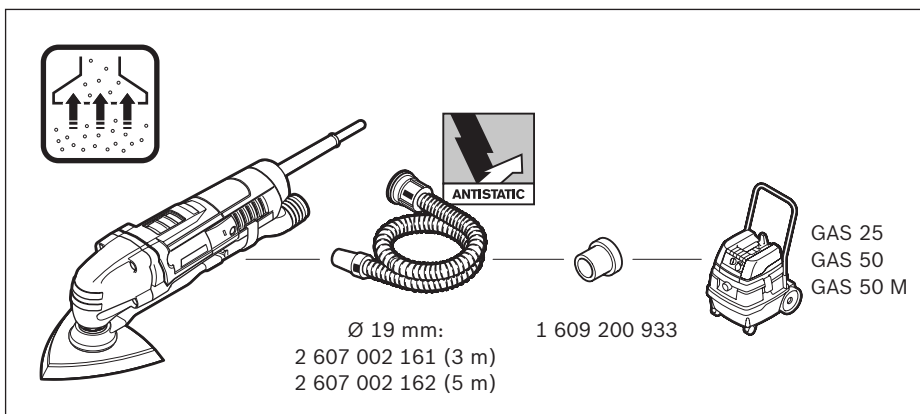
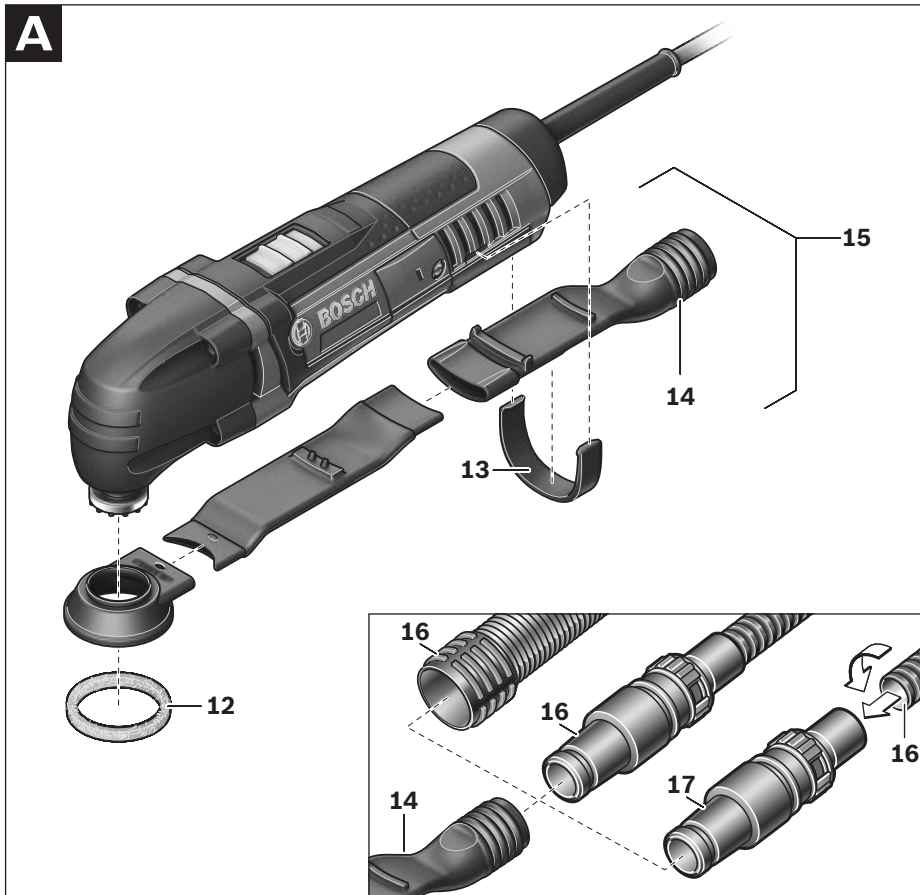

## Safety Notes

### General Power Tool Safety Warnings

**⚠ WARNING** Read all safety warnings and all instructions. Failure to follow the warnings and instructions may result in electric shock, fire and/or serious injury.

Save all warnings and instructions for future reference.

The term “power tool” in the warnings refers to your mains-operated (corded) power tool or battery-operated (cordless) power tool.

#### 1) Work area safety

- a) **Keep work area clean and well lit.** Cluttered or dark areas invite accidents.
- b) **Do not operate power tools in explosive atmospheres, such as in the presence of flammable liquids, gases or dust.** Power tools create sparks which may ignite the dust or fumes.
- c) **Keep children and bystanders away while operating a power tool.** Distractions can cause you to lose control.

#### 2) Electrical safety

- a) **Power tool plugs must match the outlet. Never modify the plug in any way. Do not use any adapter plugs with earthed (grounded) power tools.** Unmodified plugs and matching outlets will reduce risk of electric shock.
- b) **Avoid body contact with earthed or grounded surfaces, such as pipes, radiators, ranges and refrigerators.** There is an increased risk of electric shock if your body is earthed or grounded.
- c) **Do not expose power tools to rain or wet conditions.** Water entering a power tool will increase the risk of electric shock.
- d) **Do not abuse the cord. Never use the cord for carrying, pulling or unplugging the power tool. Keep cord away from heat, oil, sharp edges and moving parts.** Damaged or entangled cords increase the risk of electric shock.

- e) **When operating a power tool outdoors, use an extension cord suitable for outdoor use.** Use of a cord suitable for outdoor use reduces the risk of electric shock.
- f) **If operating a power tool in a damp location is unavoidable, use a residual current device (RCD) protected supply.** Use of an RCD reduces the risk of electric shock.

#### 3) Personal safety

- a) **Stay alert, watch what you are doing and use common sense when operating a power tool. Do not use a power tool while you are tired or under the influence of drugs, alcohol or medication.** A moment of inattention while operating power tools may result in serious personal injury.
- b) **Use personal protective equipment. Always wear eye protection.** Protective equipment such as dust mask, non-skid safety shoes, hard hat, or hearing protection used for appropriate conditions will reduce personal injuries.
- c) **Prevent unintentional starting. Ensure the switch is in the off-position before connecting to power source and/or battery pack, picking up or carrying the tool.** Carrying power tools with your finger on the switch or energising power tools that have the switch on invites accidents.
- d) **Remove any adjusting key or wrench before turning the power tool on.** A wrench or a key left attached to a rotating part of the power tool may result in personal injury.
- e) **Do not overreach. Keep proper footing and balance at all times.** This enables better control of the power tool in unexpected situations.
- f) **Dress properly. Do not wear loose clothing or jewellery. Keep your hair, clothing and gloves away from moving parts.** Loose clothes, jewellery or long hair can be caught in moving parts.
- g) **If devices are provided for the connection of dust extraction and collection facilities, ensure these are connected and properly used.** Use of dust collection can reduce dust-related hazards.

#### 4) Power tool use and care

- a) **Do not force the power tool. Use the correct power tool for your application.** The correct power tool will do the job better and safer at the rate for which it was designed.
- b) **Do not use the power tool if the switch does not turn it on and off.** Any power tool that cannot be controlled with the switch is dangerous and must be repaired.
- c) **Disconnect the plug from the power source and/or the battery pack from the power tool before making any adjustments, changing accessories, or storing power tools.** Such preventive safety measures reduce the risk of starting the power tool accidentally.
- d) **Store idle power tools out of the reach of children and do not allow persons unfamiliar with the power tool or these instructions to operate the power tool.** Power tools are dangerous in the hands of untrained users.
- e) **Maintain power tools. Check for misalignment or binding of moving parts, breakage of parts and any other condition that may affect the power tool's operation. If damaged, have the power tool repaired before use.** Many accidents are caused by poorly maintained power tools.
- f) **Keep cutting tools sharp and clean.** Properly maintained cutting tools with sharp cutting edges are less likely to bind and are easier to control.
- g) **Use the power tool, accessories and tool bits etc. in accordance with these instructions, taking into account the working conditions and the work to be performed.** Use of the power tool for operations different from those intended could result in a hazardous situation.

#### 5) Service

- a) **Have your power tool serviced by a qualified repair person using only identical replacement parts.** This will ensure that the safety of the power tool is maintained.

#### Safety Warnings for Precision Saw

- ▶ **Hold power tool by insulated gripping surfaces, when performing an operation where the cutting accessory may contact hidden wiring.** Cutting accessory contacting a "live" wire may make exposed metal parts of the power tool "live" and could give the operator an electric shock.
- ▶ **Use the machine only for dry sanding.** Penetration of water into the machine increases the risk of an electric shock.
- ▶ **Keep hands away from the sawing range. Do not reach under the workpiece.** Contact with the saw blade can lead to injuries.
- ▶ **Use suitable detectors to determine if utility lines are hidden in the work area or call the local utility company for assistance.** Contact with electric lines can lead to fire and electric shock. Damaging a gas line can lead to explosion. Penetrating a water line causes property damage or may cause an electric shock.
- ▶ **When working with the machine, always hold it firmly with both hands and provide for a secure stance.** The power tool is guided more secure with both hands.
- ▶ **Secure the workpiece.** A workpiece clamped with clamping devices or in a vice is held more secure than by hand.
- ▶ **Keep your workplace clean.** Blends of materials are particularly dangerous. Dust from light alloys can burn or explode.
- ▶ **Never use the machine with a damaged cable. Do not touch the damaged cable and pull the mains plug when the cable is damaged while working.** Damaged cables increase the risk of an electric shock.
- ▶ **Wear protective gloves when changing application tools/accessories.** Application tools/accessories become hot after prolonged usage.
- ▶ **Do not scrape wetted materials (e.g. wallpaper) or on moist surfaces.** Penetration of water into the machine increases the risk of an electric shock.

- ▶ **Do not treat the surface to be worked with solvent-containing fluids.** Materials being warmed up by the scraping can cause toxic vapours to develop.
- ▶ **Exercise extreme caution when handling the scraper.** The accessory is very sharp; danger of injury.
- ▶ **Products sold in GB only:** Your product is fitted with an BS 1363/A approved electric plug with internal fuse (ASTA approved to BS 1362).

If the plug is not suitable for your socket outlets, it should be cut off and an appropriate plug fitted in its place by an authorised customer service agent. The replacement plug should have the same fuse rating as the original plug.

The severed plug must be disposed of to avoid a possible shock hazard and should never be inserted into a mains socket elsewhere.

**Products sold in AUS and NZ only:** Use a residual current device (RCD) with a rated residual current of 30 mA or less.

## Functional Description



**Read all safety warnings and all instructions.** Failure to follow the warnings and instructions may result in electric shock, fire and/or serious injury.

While reading the operating instructions, unfold the graphics page for the machine and leave it open.

## Intended Use

The machine is intended for sawing and cutting wooden materials, plastic, gypsum, non-ferrous metals and fastening elements (e.g., unhardened nails, staples). It is also suitable for working soft wall tiles, as well as for dry sanding and scraping of small surfaces. It is especially suitable for working close to edges and for flush cutting. Operate the power tool exclusively with Bosch accessories.

## Product Features

The numbering of the product features refers to the illustration of the machine on the graphics page.

- 1 On/Off switch
- 2 Thumbwheel for orbit frequency preselection
- 3 Venting slots
- 4 Tool holder
- 5 Handle (insulated gripping surface)
- 6 Plunge saw blade\*
- 7 Clamping bolt with spring washer
- 8 Allen key
- 9 Adapter for tool holder
- 10 Sanding plate\*
- 11 Sanding sheet\*
- 12 Felt ring of the dust extraction\*
- 13 Retaining clip of the dust extraction\*
- 14 Vacuum connection\*
- 15 Dust extraction\*
- 16 Vacuum hose\*
- 17 Extraction adapter\*

**\*Accessories shown or described are not part of the standard delivery scope of the product. A complete overview of accessories can be found in our accessories program.**

## Technical Data

Precision Saw	GOP 250 CE Professional	
Article number		3 601 B30 000
Preselection of orbital stroke rate		●
Rated power input	W	250
Output power	W	150
No-load speed $n_0$	$\text{min}^{-1}$	8000–20000
Oscillation angle, left/right	°	1.4
Weight according to EPTA-Procedure 01/2003	kg	1.5
Protection class		□/II

The values given are valid for a nominal voltage [U] of 230 V. For different voltages and models for specific countries, these values can vary.

Please observe the article number on the type plate of your machine. The trade names of the individual machines may vary.

## Noise/Vibration Information

Measured sound values determined according to EN 60745.

Typically the A-weighted noise levels of the product are: Sound pressure level 81 dB(A); Sound power level 92 dB(A). Uncertainty K = 3 dB.

### Wear hearing protection!

Vibration total values (triax vector sum) determined according to EN 60745:

Sanding: Vibration emission value  $a_h = 2 \text{ m/s}^2$ , uncertainty  $K = 1.5 \text{ m/s}^2$

Cutting with plunge cut saw blade: Vibration emission value  $a_h = 10 \text{ m/s}^2$ , uncertainty  $K = 1.5 \text{ m/s}^2$

Cutting with segmental saw blade: Vibration emission value  $a_h = 6.5 \text{ m/s}^2$ , uncertainty  $K = 1.5 \text{ m/s}^2$

Scraping: Vibration emission value  $a_h = 4.5 \text{ m/s}^2$ , uncertainty  $K = 1.5 \text{ m/s}^2$ .

The vibration emission level given in this information sheet has been measured in accordance with a standardised test given in EN 60745 and may be used to compare one tool with another. It may be used for a preliminary assessment of exposure.

The declared vibration emission level represents the main applications of the tool. However if the tool is used for different applications, with different accessories or poorly maintained, the vibration emission may differ. This may significantly increase the exposure level over the total working period.

An estimation of the level of exposure to vibration should also take into account the times when the tool is switched off or when it is running but not actually doing the job. This may significantly reduce the exposure level over the total working period.

Identify additional safety measures to protect the operator from the effects of vibration such as: maintain the tool and the accessories, keep the hands warm, organisation of work patterns.

## Declaration of Conformity

We declare under our sole responsibility that the product described under "Technical Data" is in conformity with the following standards or standardization documents: EN 60745 according to the provisions of the directives 2004/108/EC, 2006/42/EC.

Technical file at:

Robert Bosch GmbH, PT/ESC  
D-70745 Leinfelden-Echterdingen

Dr. Egbert Schneider      Dr. Eckerhard Strötgen  
Senior Vice President      Head of Product  
Engineering                      Certification

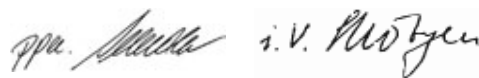

Robert Bosch GmbH, Power Tools Division  
D-70745 Leinfelden-Echterdingen  
Leinfelden, 01.07.2010









## Assembly



### Changing the Tool

- ▶ **Before any work on the machine itself, pull the mains plug.**
- ▶ **Wear protective gloves when changing application tools/accessories.** Contact with the application tool/accessory can lead to injuries.

### Selecting the Application Tool/Accessory

Accessory	Material
 HCS wood segment saw blade*	Wooden materials, plastic
 BIM segment saw blade*	Wooden materials, plastic, non-ferrous metals
 HCS plunge cut saw blades, wood*	Wooden materials, plastic, gypsum and other soft materials
 BIM plunge cut saw blades, metal*	Metal (e.g. unhardened nails, screws, smaller profiles), non-ferrous metals
 BIM plunge cut saw blade, wood and metal*	Wood, metal, non-ferrous metals
 HM-Riff segment saw blade*	Grouting joints, soft wall tiles, glass-fibre reinforces plastic and other abrasive materials
 HM-Riff delta plate*	

\* Optional accessory; for the complete accessories please see Bosch accessory programme.

Accessory	Material
 Scraper, rigid*	Carpets, coverings
 Scraper, flexible*	Silicone and other elastic materials
 Base plate for sanding, series Delta 93 mm*	Depends on sanding sheet

\* Optional accessory; for the complete accessories please see Bosch accessory programme.

### Mounting/Replacing the Application Tool/Accessory

If required, remove an already mounted application tool/accessory.

For removing the application tool/accessory, loosen the screw **7** with the Allen key **8** and remove the application tool/accessory.

Mount the requested application tool/accessory (e.g. plunge cut saw blade **6**) in such a manner on the tool holder **4** that the offset faces downward (see illustration on the graphics page; marking on the application tool/accessory is readable from above).

Turn the application tool/accessory to a position favourable for the respective job, and allow it to engage into the cams of the tool holder **4**. 12 different positions are possible, each offset by 30°. For more intermediate positions, the adapter **9** (accessory) can be used: Allow the adapter to engage with the smooth side onto the cams of the tool holder **4** (see illustration on the graphics page). Position the application tool/accessory onto the adapter in any position.

Fasten the application tool/accessory with bolt **7**. Tighten the bolt with Allen key **8** until the spring washer of the bolt faces flush against the application tool/accessory.

- ▶ **Check the tight seating of the application tool/accessory.** Incorrect or not securely fastened application tools/accessories can come loose during operation and pose a hazard.

### Mounting/Replacing a Sanding Sheet on the Sanding Plate

The sanding plate **10** is fitted with Velcro backing for quick and easy fastening of sanding sheets with Velcro adhesion.

Before attaching the sanding sheet **11**, free the Velcro backing of the sanding plate **10** from any debris by tapping against it in order to enable optimum adhesion.

Position the sanding sheet **11** flush alongside one edge of the sanding plate **10**, then lay the sanding sheet onto the sanding plate and press firmly.

To ensure optimum dust extraction, pay attention that the punched holes in the sanding sheet match with the holes in the sanding plate.

To remove the sanding sheet **11**, grasp it at one of the tips and pull it off from the sanding plate **10**.

You can use all sanding sheets, fleece pads/polishing cloth pads of the Delta 93 mm series of Bosch accessory program.

Sanding accessories, such as fleece pads/polishing cloth pads, are attached to the sanding plate in the same manner.

### Selecting the Sanding Sheet

Depending on the material to be worked and the required rate of material removal, different sanding sheets are available:

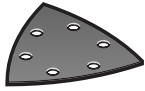
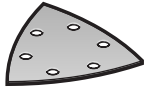
Sanding disc	Material	Application	Grain size	
 Red quality	– All wooden materials (e.g., hardwood, softwood, chipboard, building board) – Metal materials	For coarse-sanding, e.g. of rough, unplaned beams and boards	coarse	40 60
		For face sanding and planing small irregularities	medium	80 100 120
		For finish and fine sanding of wood	fine	180 240 320 400
	 White quality	– Paint – Varnish – Filling compound – Filler	For sanding off paint	coarse
For sanding primer (e.g., for removing brush dashes, drops of paint and paint run)			medium	80 100 120
		For final sanding of primers before coating	fine	180 240 320

### Dust/Chip Extraction

- ▶ Dusts from materials such as lead-containing coatings, some wood types, minerals and metal can be harmful to one's health. Touching or breathing-in the dusts can cause allergic reactions and/or lead to respiratory infections of the user or bystanders.

Certain dusts, such as oak or beech dust, are considered as carcinogenic, especially in connection with wood-treatment additives

(chromate, wood preservative). Materials containing asbestos may only be worked by specialists.

- As far as possible, use a dust extraction system suitable for the material.
- Provide for good ventilation of the working place.
- It is recommended to wear a P2 filter-class respirator.

Observe the relevant regulations in your country for the materials to be worked.

**Connecting the Dust Extraction (see figure A)**

For sanding, always connect dust extraction.

Remove the application tool/accessory when mounting the dust extraction **15** (accessory).

If required, assemble the parts of the dust extraction **15** as shown in the figure. Position the assembled dust extraction onto the machine via the tool holder **4**. Turn the dust extraction in such a manner that the cams of the dust extraction engage into the corresponding recesses on the housing. Fasten the dust extraction to the machine with the retaining clip **13** as shown in the figure.

Pay attention that the felt ring **12** is undamaged and faces tightly against the sanding plate **10**. Replace a damage felt ring immediately.

Depending on machine version, place a vacuum hose **16** (accessory) either directly onto the vacuum connection **14** or cut off the old hose end, screw the extraction adapter **17** (accessory) onto the hose end and then place it directly onto the vacuum connection **14**. Connect the vacuum hose **16** with a vacuum cleaner (accessory). An overview for the connection of various vacuum cleaners can be found on the fold-out page.

The vacuum cleaner must be suitable for the material being worked.

When vacuuming dry dust that is especially detrimental to health or carcinogenic, use a special vacuum cleaner.

**Operation**

- ▶ **Observe correct mains voltage! The voltage of the power source must agree with the voltage specified on the nameplate of the machine. Power tools marked with 230 V can also be operated with 220 V.**

**Starting Operation****Switching On and Off**

To **start** the machine, push the On/Off switch **1** forward so that the “**I**” is indicated on the switch.

To **switch off** the machine, push the On/Off switch **1** toward the rear so that the “**0**” is indicated on the switch.

**Preselecting the Orbital Stroke Rate**

With the thumbwheel for preselection of the orbital stroke rate **2**, you can preselect the required orbital stroke rate, even during operation.

The required stroke rate depends on the material and the working conditions and can be determined through practical testing.

**Working Advice**

**Note:** Do not cover off the venting slots **3** of the machine while working, as this reduces the working life of the machine.

**Operating Principle**

Due to the oscillating drive the application tool/accessory swings up to 20000 times per minute for 2.8°. This allows for precise work in narrow spaces.



Work with low and uniform application pressure, otherwise, the working performance will decline and the application tool can become blocked.



While working, move the machine back and forth, so that the application tool does not heat up excessively and become blocked.

**Sawing**

- ▶ **Use undamaged faultless saw blades only.** Deformed, blunt saw blades or saw blades that are otherwise damaged can break.
- ▶ **When sawing light building materials, observe the statutory provisions and the recommendations of the material suppliers.**
- ▶ **Plunge cuts may only be applied to soft materials, such as wood, gypsum plaster boards, etc.!**

Before sawing with HCS saw blades in wood, particle board, building materials, etc., check these for foreign objects such as nails, screws, or similar. If required, remove foreign objects or use BIM saw blades.

### Separating

**Note:** When separating wall tiles take into consideration that the application tools/accessories wear heavily when used for longer periods of time.

### Sanding

The removal rate and the sanding pattern are primarily determined by the choice of sanding sheet, the preset oscillation rate and the applied pressure.

Only flawless sanding sheets achieve good sanding capacity and extend the service life of the machine.

Pay attention to apply uniform sanding pressure; this increases the working life of the sanding sheets.

Intensifying the sanding pressure does not lead to an increase of the sanding capacity, but to increased wear of the machine and the sanding sheet.

For precise on-the-spot sanding of edges, corners and hard to reach areas, it is also possible to work only with the tip or an edge of the sanding plate.

When selectively sanding on the spot, the sanding sheet can heat up considerably. Reduce the orbital stroke rate and allow the sanding sheet to cool down regularly.

A sanding sheet that has been used for metal should not be used for other materials.

Use only original Bosch sanding accessories.

For sanding, always connect dust extraction.

### Scraping

For scraping, select a high oscillation rate.

Work on a soft surface (e.g. wood) at a flat angle, and apply only light pressure. Otherwise the scraper can cut into the surface.

## Maintenance and Service

### Maintenance and Cleaning

► **Before any work on the machine itself, pull the mains plug.**

► **For safe and proper working, always keep the machine and ventilation slots clean.**

Clean Riff application tools (accessory) regularly with a wire brush.

If the machine should fail despite the care taken in manufacturing and testing procedures, repair should be carried out by an after-sales service centre for Bosch power tools.

In all correspondence and spare parts order, please always include the 10-digit article number given on the type plate of the machine.

### After-sales Service and Customer Assistance

Our after-sales service responds to your questions concerning maintenance and repair of your product as well as spare parts. Exploded views and information on spare parts can also be found under:

**[www.bosch-pt.com](http://www.bosch-pt.com)**

Our customer service representatives can answer your questions concerning possible applications and adjustment of products and accessories.

#### Great Britain

Robert Bosch Ltd. (B.S.C.)  
P.O. Box 98  
Broadwater Park  
North Orbital Road  
Denham  
Uxbridge  
UB 9 5HJ  
Tel. Service: +44 (0844) 736 0109  
Fax: +44 (0844) 736 0146  
E-Mail: [boschservicecentre@bosch.com](mailto:boschservicecentre@bosch.com)

#### Ireland

Origo Ltd.  
Unit 23 Magna Drive  
Magna Business Park  
City West  
Dublin 24  
Tel. Service: +353 (01) 4 66 67 00  
Fax: +353 (01) 4 66 68 88

**Australia, New Zealand and Pacific Islands**

Robert Bosch Australia Pty. Ltd.  
 Power Tools  
 Locked Bag 66  
 Clayton South VIC 3169  
 Customer Contact Center  
 Inside Australia:  
 Phone: +61 (01300) 307 044  
 Fax: +61 (01300) 307 045  
 Inside New Zealand:  
 Phone: +64 (0800) 543 353  
 Fax: +64 (0800) 428 570  
 Outside AU and NZ:  
 Phone: +61 (03) 9541 5555  
 www.bosch.com.au

**Republic of South Africa****Customer service**

Hotline: +27 (011) 6 51 96 00

**Gauteng – BSC Service Centre**

35 Roper Street, New Centre  
 Johannesburg  
 Tel.: +27 (011) 4 93 93 75  
 Fax: +27 (011) 4 93 01 26  
 E-Mail: bsctools@icon.co.za

**KZN – BSC Service Centre**

Unit E, Almar Centre  
 143 Crompton Street  
 Pinetown  
 Tel.: +27 (031) 7 01 21 20  
 Fax: +27 (031) 7 01 24 46  
 E-Mail: bsc.dur@za.bosch.com

**Western Cape – BSC Service Centre**

Democracy Way, Prosperity Park  
 Milnerton  
 Tel.: +27 (021) 5 51 25 77  
 Fax: +27 (021) 5 51 32 23  
 E-Mail: bsc@zsd.co.za

**Bosch Headquarters**

Midrand, Gauteng  
 Tel.: +27 (011) 6 51 96 00  
 Fax: +27 (011) 6 51 98 80  
 E-Mail: rbsa-hq.pts@za.bosch.com

**People's Republic of China**

Website: www.bosch-pt.com.cn

**China Mainland**

Bosch Power Tools (China) Co., Ltd.  
 567, Bin Kang Road  
 Bin Jiang District 310052  
 Hangzhou, P.R.China  
 Service Hotline: 800 8 20 84 84  
 Tel.: +86 (571) 87 77 43 38  
 Fax: +86 (571) 87 77 45 02

**HK and Macau Special Administrative Regions**

Robert Bosch Hong Kong Co. Ltd.  
 21st Floor, 625 King's Road  
 North Point, Hong Kong  
 Customer Service Hotline: +852 (21) 02 02 35  
 Fax: +852 (25) 90 97 62  
 E-Mail: info@hk.bosch.com  
 www.bosch-pt.com.cn

**Indonesia**

PT. Multi Tehaka  
 Kawasan Industri Pulogadung  
 Jalan Rawa Gelam III No. 2  
 Jakarta 13930  
 Indonesia  
 Tel.: +62 (21) 46 83 25 22  
 Fax: +62 (21) 46 82 86 45/68 23  
 E-Mail: sales@multitehaka.co.id  
 www.multitehaka.co.id

**Philippines**

Robert Bosch, Inc.  
 28th Floor Fort Legend Towers,  
 3rd Avenue corner 31st Street,  
 Fort Bonifacio Global City,  
 1634 Taguig City, Philippines  
 Tel.: +63 (2) 870 3871  
 Fax: +63 (2) 870 3870  
 matheus.contiero@ph.bosch.com  
 www.bosch-pt.com.ph  
 Bosch Service Center:  
 9725-27 Kamagong Street  
 San Antonio Village  
 Makati City, Philippines  
 Tel.: +63 (2) 899 9091  
 Fax: +63 (2) 897 6432  
 rosalie.dagdagan@ph.bosch.com

**Malaysia**

Robert Bosch (S.E.A.) Pte. Ltd.  
 No. 8A, Jalan 13/6  
 G.P.O. Box 10818  
 46200 Petaling Jaya  
 Selangor, Malaysia  
 Tel.: +60 (3) 7966 3194  
 Fax: +60 (3) 7958 3838  
 cheehoe.on@my.bosch.com  
 Toll-Free: 1800 880 188  
 www.bosch-pt.com.my

**Thailand**

Robert Bosch Ltd.  
 Liberty Square Building  
 No. 287, 11 Floor  
 Silom Road, Bangrak  
 Bangkok 10500  
 Tel.: +66 (2) 6 31 18 79 – 18 88 (10 lines)  
 Fax: +66 (2) 2 38 47 83  
 Robert Bosch Ltd., P. O. Box 2054  
 Bangkok 10501, Thailand  
 Bosch Service – Training Centre  
 2869-2869/1 Soi Ban Kluay  
 Rama IV Road (near old Paknam Railway)  
 Prakanong District  
 10110 Bangkok  
 Thailand  
 Tel.: +66 (2) 6 71 78 00 – 4  
 Fax: +66 (2) 2 49 42 96  
 Fax: +66 (2) 2 49 52 99

**Singapore**

Robert Bosch (SEA) Pte. Ltd.  
 11 Bishan Street 21  
 Singapore 573943  
 Tel.: +65 6571 2772  
 Fax: +65 6350 5315  
 leongheng.leow@sg.bosch.com  
 Toll-Free: 1800 333 8333  
 www.bosch-pt.com.sg

**Vietnam**

Robert Bosch Vietnam Co. Ltd  
 10/F, 194 Golden Building  
 473 Dien Bien Phu Street  
 Ward 25, Binh Thanh District  
 84 Ho Chi Minh City  
 Vietnam  
 Tel.: +84 (8) 6258 3690 ext. 413  
 Fax: +84 (8) 6258 3692  
 hieu.lagia@vn.bosch.com  
 www.bosch-pt.com

**Disposal**

The machine, accessories and packaging should be sorted for environmental-friendly recycling.

Do not dispose of power tools into household waste!

**Only for EC countries:**

According to the European Guideline 2002/96/EC for Waste Electrical and Electronic Equipment and its implementation into national right, power tools that are no longer usable must be collected separately and disposed of in an environmentally correct manner.

**Subject to change without notice.**